

# MOTORISED EXTERNAL VENETIANS

The advanced external venetian blind system that provides optimal heat protection and unsurpassed light control. Perfect for domestic or commercial environments, the slats let in natural sunlight whilst minimising uncomfortable hothouse effects and eliminating blinding glare.

Featuring a range of stylish 60/70/80/90mm curved and flat slats with baked enamel finish offering options such as rolled edges to provide extra stability/anti vibration, The external venetians suit any external façade and come in a range of modern designer colours and can be controlled by switch, hand held remote control or automated building management systems.

The elegant slats can be set to any position by raising, lowering and tilting to allow room temperature and light level to be perfectly matched to user requirements. when fully retracted system provides a completely un-obstructed view.

Unaffected by extreme temperature changes, the external venetians reduce the sun's penetration by up to 90% providing airconditioning cost efficiencies. Whether you are an architect looking for a solution to help attain a Green Star™ rating for an office block or you're conscious about your own needs in the home – the external venetian range has your environmental concerns covered. Its offers a practical and robust intelligent sun control solution – satisfying the most ambitious design demands of modern architecture.

## GUIDING OPTIONS

- 2mm stainless steel cable guiding – sheathed in PVC for added anti-corrosion and noise reduction
- 18 x 36mm extruded aluminium side channel with noise reducing lining
- Adjustable fixing brackets adjust side guides from 55 to 74mm from wall (or custom sizes on request)
- Optional reveal fixing, recessed, self-supporting, coupled and circular side channel options also available.

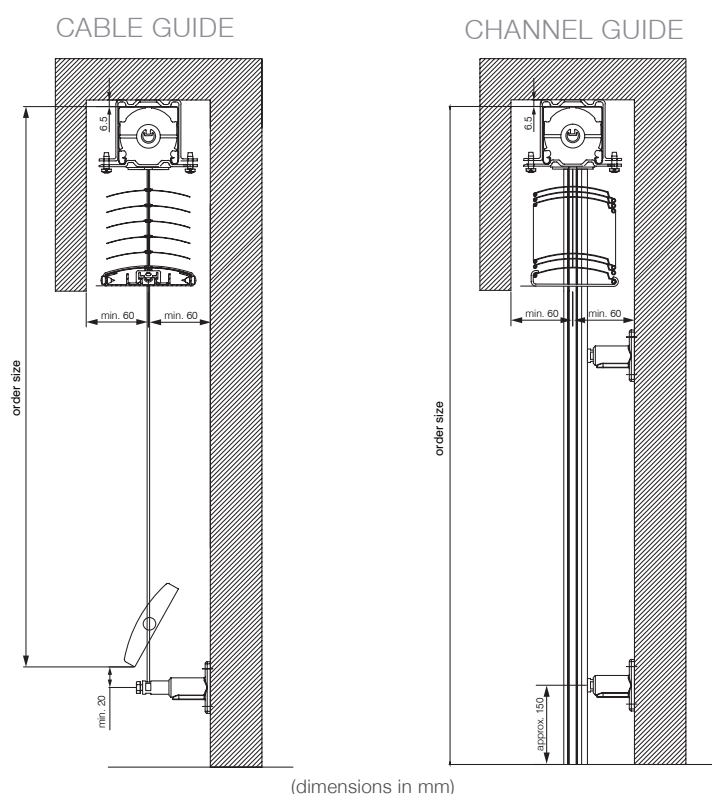
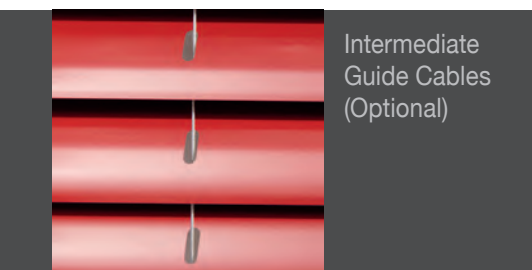
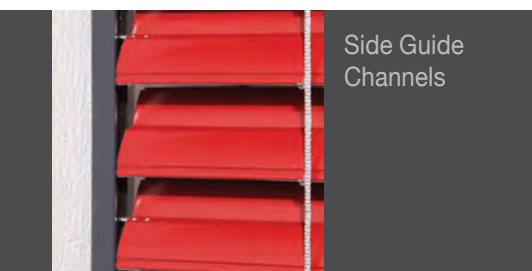
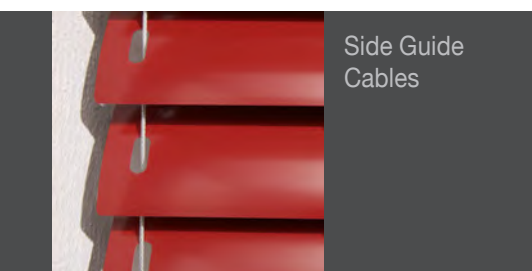







## THE HELIOSCREEN DIFFERENCE

- Automated Wind/Sun/Rain-sensing controls to tilt and retract blinds when needed
- UV resistant components, lifting tapes and ladder cords for extended life in exposed environments
- Extruded aluminium base rail profile for increased stiffness and rail weight
- Extensive range of Slats to suit every application for both commercial and domestic
- Precision Extruded Drive shaft for fine tilt control
- Direct drive motor for increased performance and reliability
- Integrated heavy duty side cable / guide attachment head for increased wind resistance
- High grade stainless steel fixtures suitable for coastal environments
- Optional extruded aluminium pelmets powder coated in a range of colours.

## FEATURES

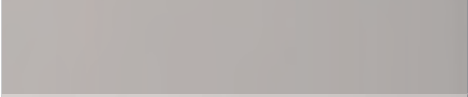
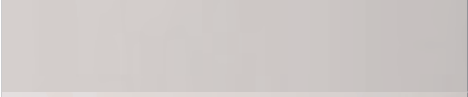
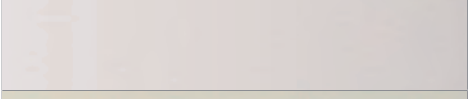
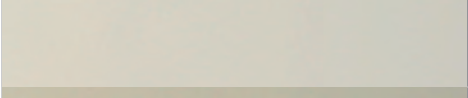
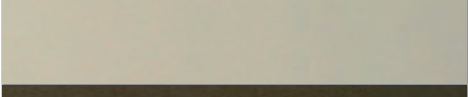
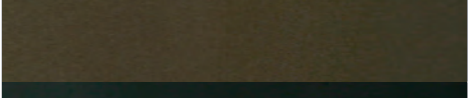
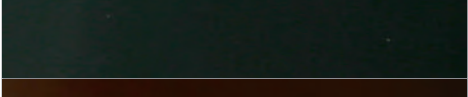
- 5 year warranty
- Width 700-5000mm
- Maximum drop 5000mm
- Available in a range of colours
- Motorised operation
- Remote control option
- Automatic control with optional sun and wind sensor.

## SLAT COLOURS

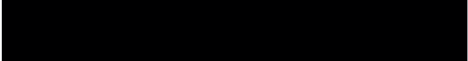
	<b>VSR 140</b> Silver
	<b>VSR 907</b> Grey alumin
	<b>VSR 130</b> Grey
	<b>VSR 904</b> Light grey
	<b>VSR 010</b> White
	<b>VSR 1013</b> Pearl White
	<b>VSR 240</b> Light Beige
	<b>VSR 780</b> Bronze
	<b>VSR 7016</b> Anthracite
	<b>VSR 071</b> Dark brown
	<b>VSR 330</b> Purple red
	<b>VSR 220</b> Moss green
	<b>VSR 9005</b> Black (C80 slat only)





## EXTERNAL VENETIANS – SLAT SELECTION CHART



**C Slats**  
80mm

Dual integrated beaded slat edges for perfect alignment and optimum performance with stylish curved visual finish when in use.

**Slat tilting range of 160°**

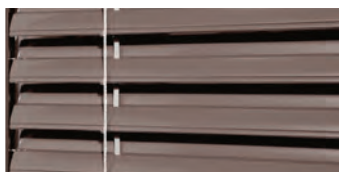

**Z Slats**  
70 & 90mm

Offers increased light dimming thanks to overlapping closure of slats which have integrated dampening lip rolled in to the leading edge.

**Slat tilting range of 90°**



**F Slats**  
80mm

Highly flexible flat slat offers a streamline external view when down combined with a compact slat stack when retracted.

**Slat tilting range of 160°**

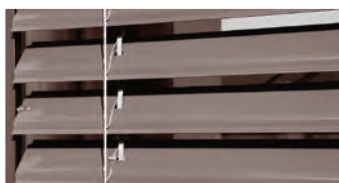

**T Slats**  
60 & 80mm

Are the perfect solution for modern architecture, offering linear symmetry with clean lines and reduces stacking height.

**Slat tilting range of 160°**

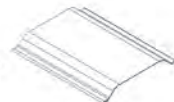

### INDOOR AND OUTDOOR RANGE

 90% Reduced Heat Radiation  Windsensor Retractor

 5 Year Warranty

 Powered by Somfy 5-year motor warranty

Includes: Roller Blinds, Roman Blinds, Panel Glides, Blackouts, External Screens, Awnings, External Venetians, and Retractable Roof Systems.